

SPECIFICATIONS

Current Rating: 1 Amps
 Insulator Resistance: 100 Megohms min. @ 500VDC
 Contact Resistance: 50 Megohms Max
 Voltage Rating: 30V AC
 Dielectric withstanding: 100V AC
 Durability (Life Test): 5000 Cycles
 Insertion Force: 35 Newton Max.
 Extraction Force: 7 Newton Min.

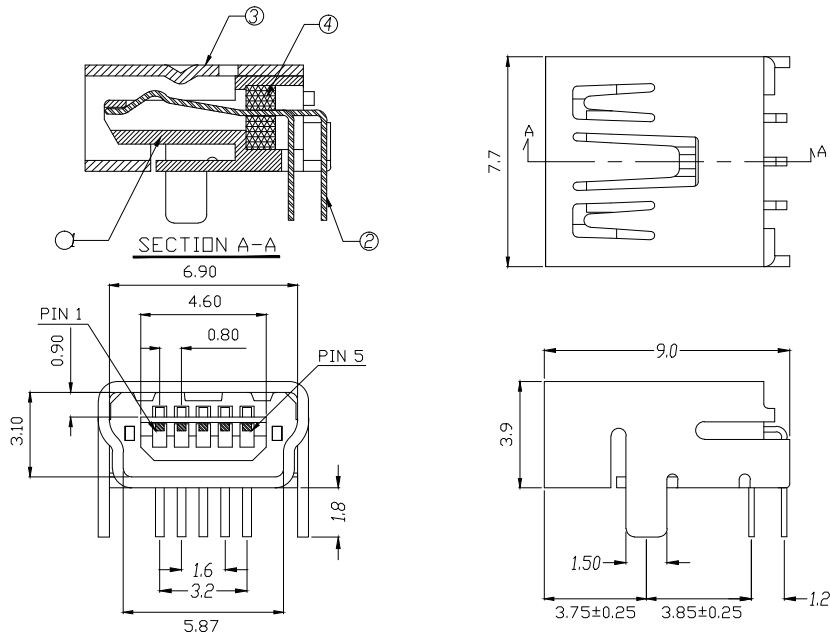

BPOM 05 XX VX X-FG
 1 2 3 4 5 6

- | | |
|---|---|
| <p> 1.SERIES NO.
 BPOM=USB Mini Type B
 2.CONTACT NUMBER:
 05=05 PINS
 3.CONTACT TYPE:
 F3=FEMALE(Nylon PA9T) </p> | <p> 4.CONTACT AREA PLATING:
 VA=Tin Plated
 VB=Gold Plated
 5.Shell PLATING:
 N=Nickel Plated
 K=Tin Plated (Matte)
 6.Green Option:
 FG=RoHS Compliant </p> |
|---|---|

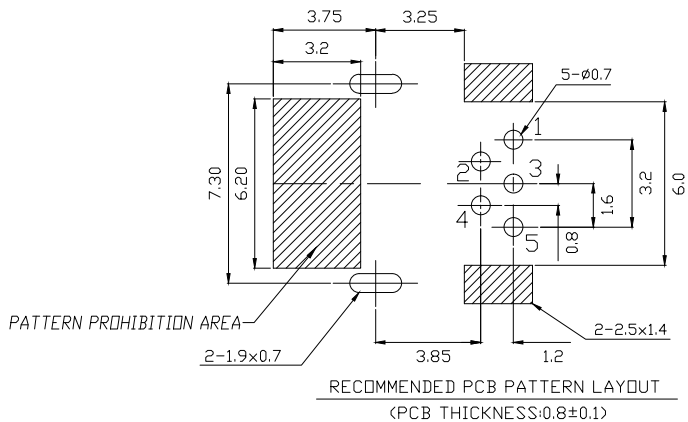

APTOS Technology CONFIDENTIAL
 This document, and all information it contains, are the confidential, proprietary property of APTOS Technology. Disclosure, duplication or distribution of this document, or any information it contains, in whole or part, without prior written permission from APTOS Technology is strictly prohibited

NO.	NAME	MATERIAL	FINISH	Q'TY	REMARK
1	HOUSING	NYLON PA9T G.F	BLACK	1	
2	PIN TERM.	PBS T:0.2	GOLD/TIN PLATED	5	Gold:30u"; NI:40~60u"; TIN:120u" (100% pure Tin of lead free plating)
3	SHELL	BRASS T:0.4	NICKEL PLATED	1	Ni:80~120u"
4	CENTER PASTERN	NYLON PA9T G.F	BLACK	1	

GENERAL TOLERANCE UNLESS OTHERWISE SPECIFIED	
XXX. ± X	.XX ± 0.10
XX. ± X	.XXX ± X
X. ± 0.50	X. ± 1"
.X ± 0.30	.X ± X"



REV. A	DRAWN	09/15/09	BPOM Series Mini USB - Type B
DATE 09/15/09	CHECKED		
SCALE As shown	APPROVED		PRODUCT NO. BPOM-05-XX-VX-X-FG
UNIT mm		SIZE A4	FILE NAME: BPOM-05-XX-VX-X-FG.dwg